

1. Description;

The E-MAAX PRO X continues the development program of the previous E-MAAX models, with enhancements driven by customer requests and industry standard for NMEA connectivity.

E-MAAX PRO X Regulator optimizes alternator output based on;

- System load
- Battery type
- Current and voltage sensing

The battery charging profile is programmed based of battery type for the common batteries (Lead Acid / AGM / Gel / FireFly / Custom-LiFePO₄ / "LiFePO₄ MAAX") in both 12 and 24 Volt and "P" or "N" alternator configurations. The PRO X has two LED's which function as visual status indicators and fault diagnostics.



2. Specifications

Parameter	Value	Units
Weight	200	grams
Housing material	PVC	-
Operating range	-20 .. +100	Celsius deg
Protection	IP 56	-
Maximum allowable shock	3	G
Maximum allowable relative humidity	95	%

3. Dimensional outline

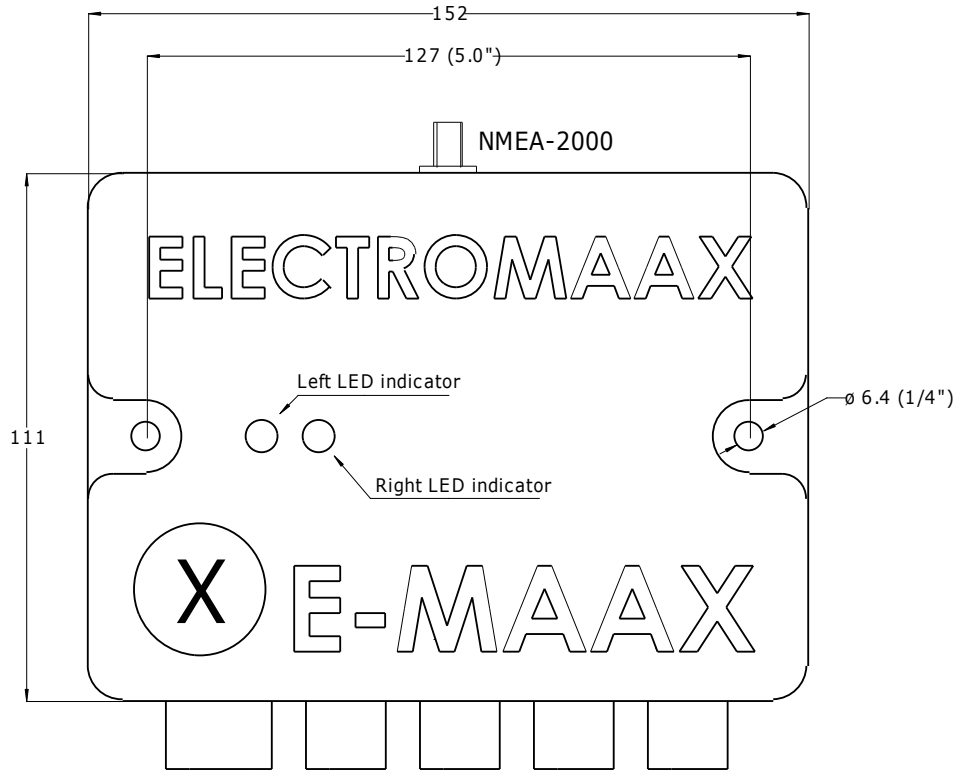

All units are millimeters (inches)

3. Electrical specifications

Parameter	Value	Units
Maximum supply voltage	40	Volts
Current consumption	Up to 0.150	Amps
Maximum Field current	20	Amps
Maximum voltage at Battery Voltage Sensor leads	40	Volts
Maximum voltage at Alternator Current Shunt leads	40	Volts
Maximum voltage at Battery Current Shunt leads	5	Volts
Power Cable ratings	Gauge: 14 AWG Material: tinned copper strands Insulator Material: PVC Jacket Color: black Diameter: 13 mm Insulation: up to 300 Volts	-
Signal and Sensing Leads ratings	Gauge: 18 AWG Material: tinned copper strands Insulator Material: PVC Insulation: up to 300 Volts	-

Refer to the connectors diagram below for additional connection information on cables. The diagram shows a regulator view from the connectors side.

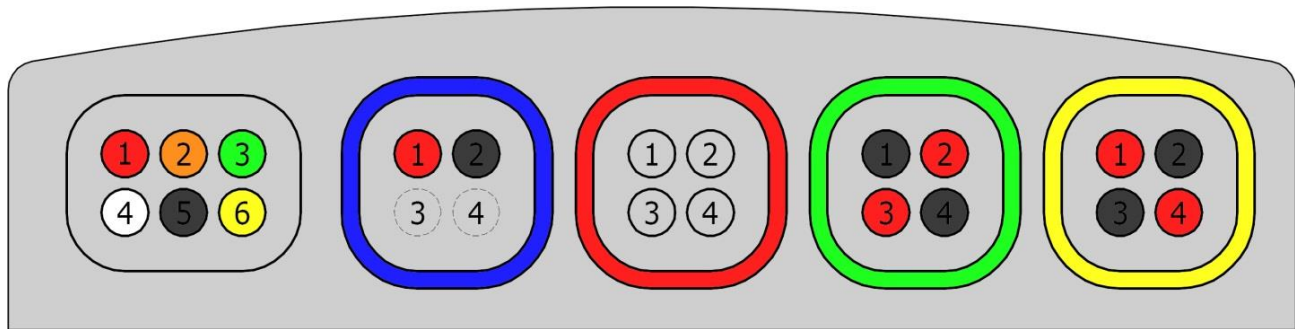

Cable	Color Code	Pin	Pin Color	Function	Connects to
Power Harness	None	1	Red	Battery Positive	B+ post of the alternator
		2	Brown	Field Output #1	F post of the alternator
		3	Green	Field Output #2	F post of the secondary alternator
		4	White	Ignition Input	B+ post of the alternator
		5	Black	Battery Ground	case of the alternator
		6	Yellow	Tachometer Input	W post of the alternator
Alternator Temperature sensing	Blue	1	Red	Sensor lead	case of the alternator
		2	Black	Sensor lead	
		3	Not Connected	-	
		4	Not Connected	-	
Regulator-to-regulator communication	Red	1	-	OUT-	"IN-" at another Pro X
		2	-	OUT+	"IN+" at another Pro X
		3	-	IN+	"OUT+" at another Pro X
		4	-	IN-	"OUT-" at another Pro X
Battery Voltage and Temperature sensing	Green	1	Red	Sensor lead	
		2	Black	Sensor lead	
		3	Red	Sensor lead	B+ post of the battery
		4	Black	Sensor lead	B- post of the battery
Battery and Alternator Current sensing	Yellow	1	Red	BH lead	Battery Current Shunt
		2	Black	BL lead	Battery Current Shunt
		3	Black	AL lead	Alternator Current Shunt
		4	Red	AH lead	Alternator Current Shunt

Notes:

- **Battery leads are 3M in length and Alternator leads are 2M in length.**
- **Ensure the voltage at the Battery Current Shunt leads, BH and BL, is NOT greater than 5V in respect to the Battery Ground.**
- **Make sure the harness color codes match that of the regulator connectors.**

Diagram of one shoulder of the regulator-to-regulator communication is shown below to illustrate the connection of the communication cable between two PRO X regulators.

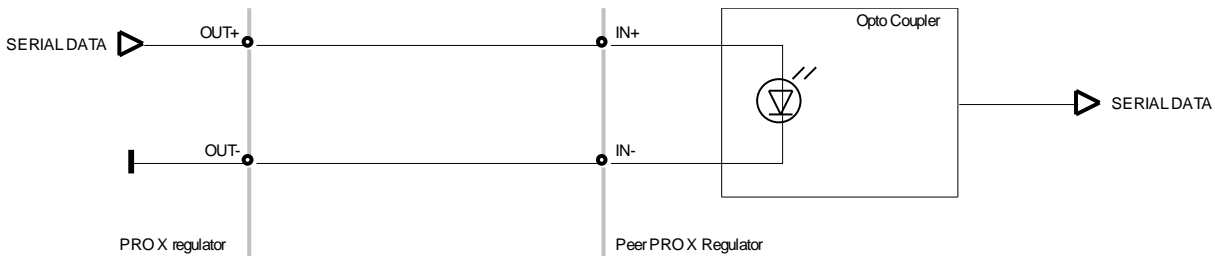



4. Description of functions

The PRO X regulator provides alternator output by controlling the “Field” input into the alternator. As the Field signal is increased or decreased so the alternator output follows. The term Field Output refers to Field condition from the Regulator, whereas Field Input is the same value from the Alternator’s perspective.





Visual Indication

PRO X Regulator has two LED indicators.

Left indicator works only when the ignition is inactive and there is no regulation.

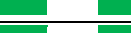
Lighting sequence	Meaning
	Regulator is powered up, ignition is switched off. It flashes green every 1 seconds.
	Regulator is busy reporting its settings to external PC
	Regulator is busy updating its settings from external PC

Right indicator works only when the ignition is active and there is regulation.

Lighting sequence	Meaning
	Warm-up stage of regulation
	Bulk+Absorb stage of regulation
	Float stage of regulation
	Warning or Reduced Field condition
	<i>Critical Fault condition</i> , when regulator disables the alternator’s output
	SLAVE mode of regulation

Supported Optional Peripherals:

PRO X Regulator supports any of the following peripherals:

- Alternator Temperature Sensor
- Battery Temperature Sensor
- Alternator Current Measurement Shunt
- Battery Current Measurement Shunt
- Battery Voltage Sensor

The peripherals can be hot-plugged at any time into any available port without restarting the regulator. The regulator detects the presence of any compatible peripheral and acquires data from it automatically.

Charging stages and supported chemistries:

X Regulator supports the following battery chemistries, in both 12 and 24 Volts:

- a) Lead-acid
- b) AGM
- c) Gel
- d) Carbon Foam
- e) Lithium MAAX LiFePO4
- f) Lithium
- g) 2 custom profiles

Upon the activation of the Ignition lead, the PRO X Regulator regulates the battery charge through the following charge profile stages:

- a) Warm-up
- b) Bulk + Absorb
- c) Float

Depending on the charging conditions, such as immediate load requirements and engine speed, the PRO X Regulator switches between the charge profile stages to achieve the optimal charging.

Field reduction:

When connected to the PRO X regulator via Wi-Fi, the webpage allows reduction of the regulator's Field Output to divert engine power from generating electricity to the propellers if needed. Each screen button press reduces Field Output in 10% increments, down to 30% of its nominal value for the current charging conditions. Field reduction is indicated by the right LED flashing red once and is re-set automatically when the ignition is switched off.

Warning condition:

Warning condition is a special mode of regulation when the Field Outputs are reduced to 50% of their nominal value for the current charging conditions. The regulator is placed into the Warning condition due to one or more of the following conditions:

- a) Elevated battery's temperature
- b) Elevated alternator's temperature
- c) Elevated battery's voltage
- d) Voltage Drop in cabling is too large

The Warning condition is indicated by the right LED flashing red once. Warning condition is re-set automatically when the ignition is switched off.

Fault condition:

Fault condition is an alarm mode (right LED flashing red two times quickly) when Field output is disabled in order to avoid damage to the charging system. The regulator is placed into the Fault condition due to one or more of the following conditions:

- a) The regulator's temperature reaches 70°C
- b) Internal regulator hardware malfunction
- c) The battery's temperature exceeds its maximum allowed value
- d) The battery's voltage exceeds its maximum allowed value
- e) The alternator's temperature its maximum allowed value
- f) In-line fuse on the power supply line is blown (and ignition is ON)

Critical Fault condition does not require restart of the regulator; it is re-set automatically when the fault condition is cleared.

SLAVE regulation mode:

SLAVE is a fail-safe mode of regulation when the Pro X regulator is being supervised by another Pro X regulator on another engine. 4-wire communication connection is required between the two Pro X regulators installed on two engines charging same battery. This mode is indicated with one short blue flash of the right LED.

Current Measurements:

After having established the required connection to the battery and alternator shunts, the regulator must be adjusted to zero the current measurement. This is due to the resistivity of the wiring elements the current measurement shunts are connected with. This is achieved by rotating the appropriate trimmer potentiometers while the system is in resting state, i.e. no current is flowing through it.

To calibrate the alternator leads, the "Calibrate Alternator Current Lead" menu command must be invoked.

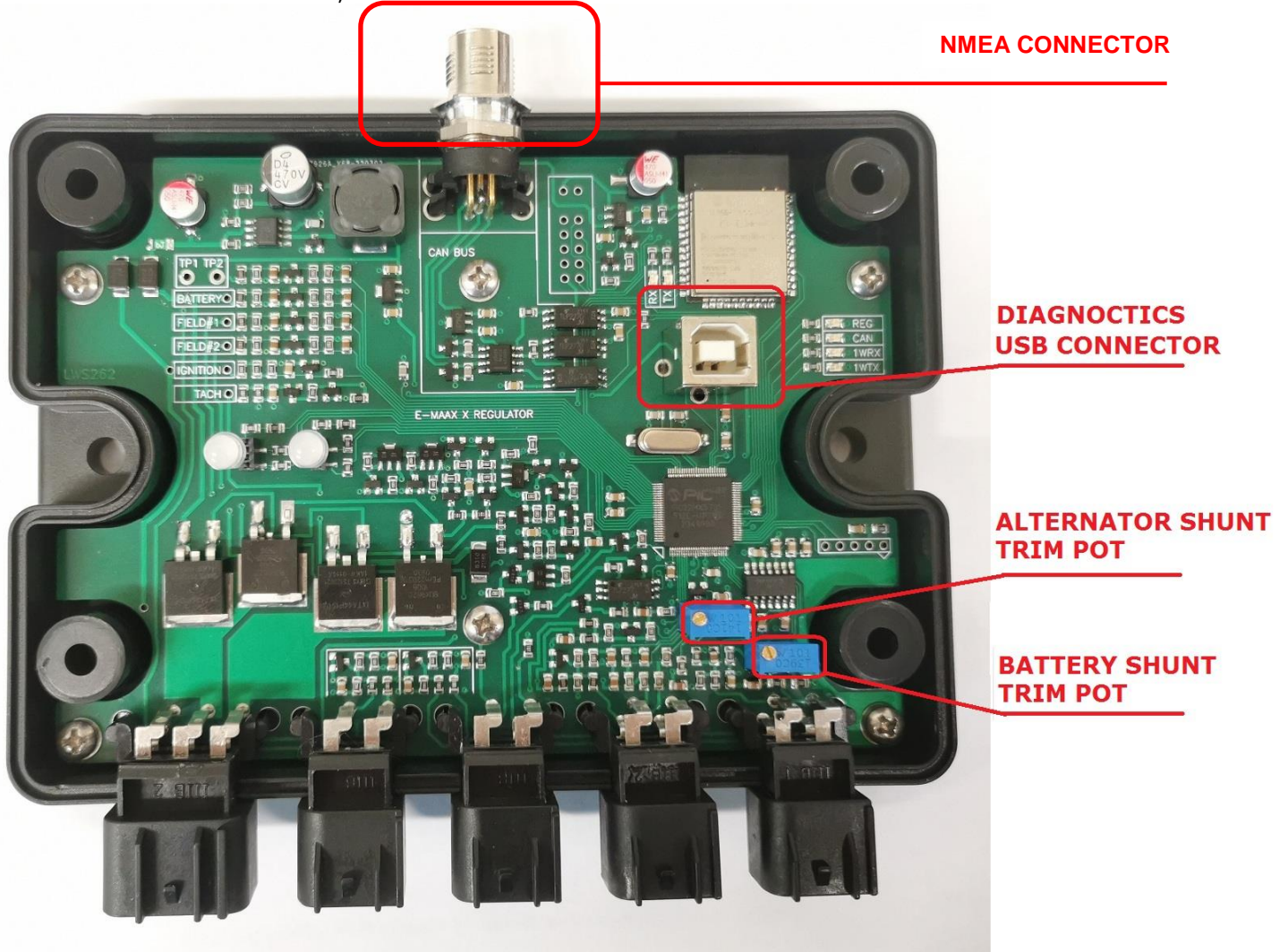

4. USB interface

USB interface is provided for full access to the device's parameters. It connects to a PC via the **EMx.exe** application. The application is available to download from the ElectroMaax website www.electromaaxsupport.com/EmX.zip System State, as well as the Peer System State (Peer System is another X regulator which is connected to the one where USB interface is being used), is refreshed each half second to provide monitoring and troubleshooting capabilities during the system install and commissioning. To gain access to the USB connection, the top cover of the regulator must be removed.

Regulator Settings:

With the application it is possible to view and modify the device’s settings to suit a particular installation.

“Save Setting To File” stores the screen values to a file.

“Load Setting From File” brings to the screen settings stored in a file.

“Read Settings” brings to the screen actual stored settings from the connected Pro X regulator.

“Write Settings” stores the screen values to the connected Pro X regulator.

“Reset Settings to Default Values” makes the connected Pro X regulator revert to the factory settings.

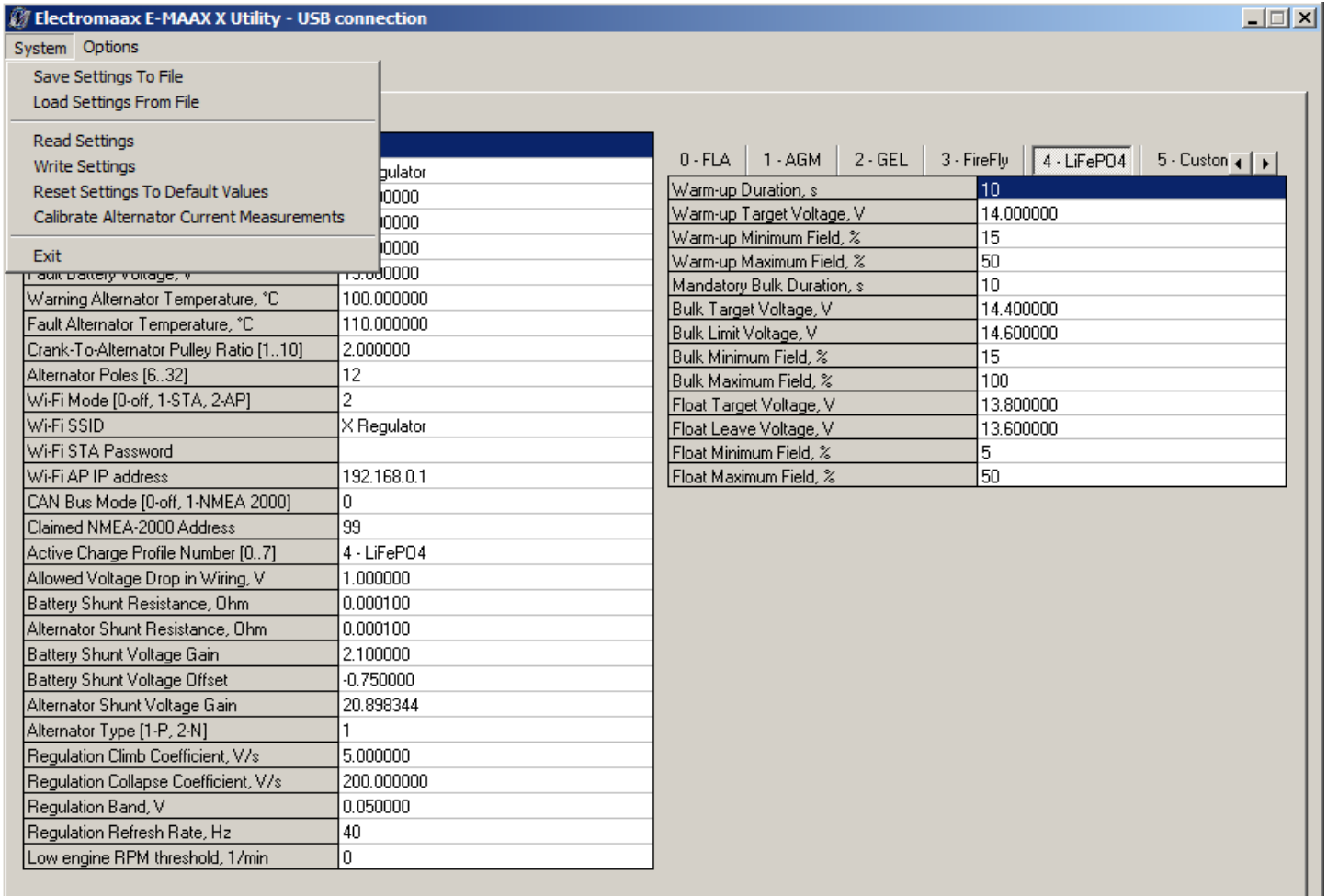

Refer to the table below for the description of the available settings

Parameter	Meaning	Valid Range	Units
Device Version	Firmware version, set at the factory	-	-
Device Name	String up to 16 characters long to identify the X regulator on webpage and when there are 2 X regulators in the system.	-	-
Warning Battery Temperature	House Battery temperature above which the alternator’s output is limited to 50% to avoid overheating. Set to 0 if the feature is not used.	30-50	°C

Fault Battery Temperature	House Battery temperature above which the alternator's output is cut to avoid overheating. Set to 0 if the feature is not used.	40-60	°C
Warning Battery Voltage	System voltage above which the alternator's output is limited to 50%. Set to 0 if the feature is not used.	10-30	Volts
Fault Battery Voltage	System voltage above which the alternator's output is cut. Set to 0 if the feature is not used.	10-30	Volts
Warning Alternator Temperature	Alternator temperature above which the alternator's output is limited to 50% to avoid overheating. Set to 0 if the feature is not used. The feature works only when the Alternator Temperature sensor is connected to the regulator.	70-100	°C
Fault Alternator Temperature	Alternator temperature above which the alternator's output is cut to avoid overheating. Set to 0 if the feature is not used. The feature works only when the Alternator Temperature sensor is connected to the regulator.	70-110	°C
Wi-Fi Mode	0-Wi-Fi module is disabled 1- Wi-Fi module presents as a device in an existing local network, and can be connected to as to a client with a local address, i.e. supports one connection at a time. (Station Mode) 2- Wi-Fi module presents as a server and produces own local network, and can be connected to as to a website with a local address, i.e. supports multiple connections. (Access Point Mode)	0 or 1 or 2	-
Wi-Fi SSID	String up to 32 characters long. While in Station Mode, indicates the name of an existing Wi-Fi network to connect to. While in Access Point mode, sets the name of the Wi-Fi network created by the X regulator, so client can connect to it.	-	-
Wi-Fi STA Password	String up to 32 characters long. While in Station Mode, indicates the password required to connect to an existing Wi-Fi network. While in Access Point mode, no password required to connect to the Wi-Fi network created by the PRO X regulator.	-	-
Wi-Fi AP IP Address	While in Access Point mode, sets the IP address of the server of the Wi-Fi network created by the X regulator.		
CAN Bus Mode	0 - CAN communications are disabled 1- Allows CAN communications for the PRO X regulator when connected to an NMEA-2000 network.	0 or 1	-
Claimed NMEA-200 Address	A number to identify the PRO X regulator on the NMEA-2000 network. Must be a unique number for each PRO X regulator in the system. It may also be displayed as the "Serial Number", or as the "Device Instance"	0-255	-
Active Charge Profile Number	Zero-based index to identify the House Battery chemistry used. 0 - FLA, or Lead-acid 1 - AGM 2 - GEL 3 - Carbon Foam, or FireFly 4 - Lithium MAAX LiFePO4 5 - generic Lithium 6 - custom Profile 7 - custom Profile This parameter is changed by clicking on different profile names of the regulation settings.	0-7	-
Allowed Voltage Drop In Wiring	When the wiring voltage drop exceeds this value, the alternators' output is limited to 50% to avoid equipment damage. Default value is 1.0.	2	Volts

Battery Shunt Resistance	Battery Shunt Resistance used to calculate the battery current. Can be derived from the shunt designation. For instance, "50mV/500A" means that the Shunt Resistance is 0.0001. Set to 0 if the feature is not used.	0-0.1	Ohms
Alternator Shunt Resistance	Battery Shunt Resistance used to calculate the battery current. Can be derived from the shunt designation. For instance, "50mV/500A" means that the Shunt Resistance is 0.0001. Set to 0 if the feature is not used.	0-0.1	Ohms
Alternator Type	Set to 1 if a P-type alternator is used; set to 2 if a N-type alternator is used.	1 or 2	-
Regulation Climb Coefficient	This parameters sets the pace at which the regulator tries to achieve the set voltage when the set voltage is greater than the immediate system voltage. Default value = 5	1-100	Volts/sec
Regulation Collapse Coefficient	This parameters sets the pace at which the regulator tries to achieve the set voltage when the set voltage is lesser than the immediate system voltage. Default value = 200	1-400	Volts/sec
Regulation Band	Tolerance to target of the voltage-based regulation. Default=.05	0.01-0.5	Volts
Regulation Refresh Rate	Sets the pace at which the regulator refreshes itself. Default = 40	20-200	Hz
Crank-to-Alternator Pulley Ratio	Actual "Crank Pulley Diameter" to "Alternator Pulley Diameter" ratio. This parameter is used to calculate the engine RPM.	1-10	-
Alternator Poles	Number of the poles in the alternator used. Refer to the alternator manufacturer's datasheet. This parameter is used to calculate the engine RPM.	6-30	-
Low Engine RPM Limit	Engine RPM value below which the alternator's output is limited to 50% to avoid engine stall. Set to 0 is the feature is not used.	0-1000	rpm

System State and Peer System State:

Displayed information is separated into the following groups: Measured Values, System State, Regulator State, and Messages.

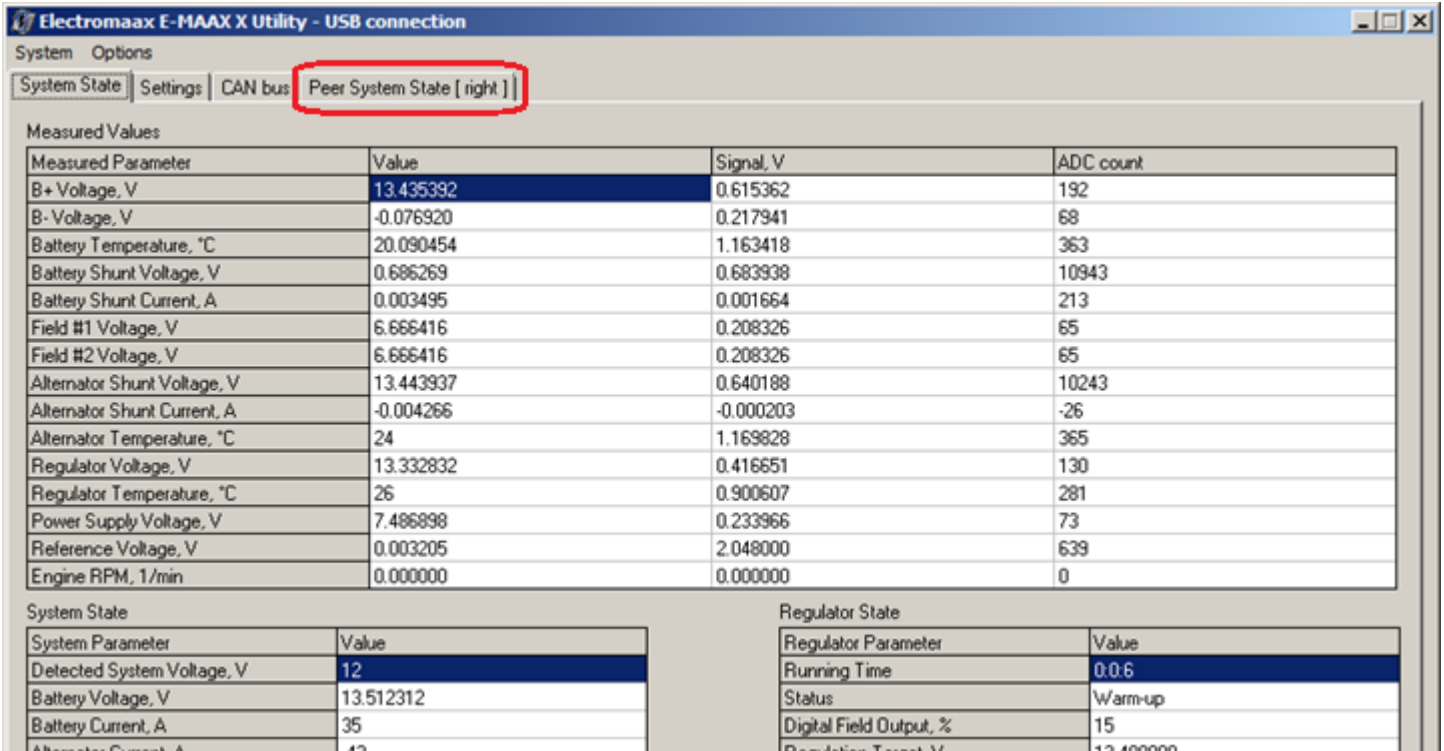

The screenshot shows the 'Electromaax E-MAAX X Utility - USB connection' window. The 'Peer System State [right]' tab is selected. The 'Measured Values' table lists various parameters with their values, signals, and ADC counts. The 'System State' and 'Regulator State' tables provide additional diagnostic information.

Measured Parameter	Value	Signal, V	ADC count
B+ Voltage, V	13.435392	0.615362	192
B- Voltage, V	-0.076920	0.217941	68
Battery Temperature, °C	20.090454	1.163418	363
Battery Shunt Voltage, V	0.686269	0.683938	10943
Battery Shunt Current, A	0.003495	0.001664	213
Field #1 Voltage, V	6.666416	0.208326	65
Field #2 Voltage, V	6.666416	0.208326	65
Alternator Shunt Voltage, V	13.443937	0.640188	10243
Alternator Shunt Current, A	-0.004266	-0.000203	-26
Alternator Temperature, °C	24	1.169828	365
Regulator Voltage, V	13.332832	0.416651	130
Regulator Temperature, °C	26	0.900607	281
Power Supply Voltage, V	7.486898	0.233966	73
Reference Voltage, V	0.003205	2.048000	639
Engine RPM, 1/min	0.000000	0.000000	0

System Parameter	Value
Detected System Voltage, V	12
Battery Voltage, V	13.512312
Battery Current, A	35
Alternator Current, A	42

Regulator Parameter	Value
Running Time	0.0.6
Status	Warm-up
Digital Field Output, %	15
Regulation Target, V	13.400000

Measured Values are raw electrical signals measured by the regulator’s microcontroller via the harness sensing leads. The Measured Values are shown for the diagnostic purposes. Each Measured Value has 3 numbers associated with it: Value, Signal, and ADC Count.

Signal is the voltage at the corresponding microcontroller’s pin; it must be within 0 and 2 Volts. ADC Count is the result of analog-to-digital conversions. Valid range for ADC Count is between 0 and 2047 (11 bits), except for the Shunt measurements between -32767 and 32767 (16 bits).

Parameter value: such as; temperature, voltage, etc.

ADC Count being outside its valid range means a microcontroller fault. Signal outside its range means faulty connections of the sensing leads. Value outside of its range means incorrect installation or charging system faults.

Parameter	Meaning	Units
B+ Voltage	Measured voltage at the “B+” post of the alternator in respect to the battery’s ground.	Volts
B- Voltage	Measured voltage at the “B-” post of the alternator in respect to the battery’s ground. Can be negative due to the voltage drop in wiring.	Volts
Battery Temperature	Measured temperature of the battery	°C
Battery Shunt Voltage	Voltage at the battery shunt; must be equal to “B- Voltage”	Volts
Battery Shunt Voltage Drop	Voltage drop across the battery shunt due to the battery current. Can be positive or negative.	Volts
Field #1 Voltage	Voltage on the “F” post of the alternator	Volts
Field #2 Voltage	Voltage on the “F” post of the secondary alternator	Volts
Alternator Shunt Voltage	Voltage at the Alternator Shunt; must be equal to “Regulator Voltage”	Volts

Alternator Shunt Voltage Drop	Voltage drop across the alternator shunt due to the charging current. Can be positive.	Volts
Alternator Temperature	Calculated alternator temperature based on the temperature sensor signal.	°C
Regulator Voltage	Voltage at the back of the alternator	Volts
Regulator Temperature	Temperature inside the regulator's enclosure; should not exceed 60	°C
Power Supply Voltage	Voltage used to power the internal regulator's circuitry; must be approximately 7.5	Volts
Reference Voltage	Voltage used for analog-to-digital conversions; must be 2.048	Volts
Engine RPM	Calculated engine RPM value based on the measured frequency of the tachometer pulses on the "W" post of the alternator.	rpm

System State parameters are not measured directly, but calculated from the Measured Values or set by the software according to the current operating conditions.

Parameter	Meaning	Units
Detected System Voltage	On power-up, while the X Regulator runs self-diagnostic and start-up procedures for a few seconds, it also auto-detects the system voltage and adjusts the regulation parameters to it. Possible values are 12, 24, or 0 (not detected).	Volts
Battery Voltage	If the voltage sensing harness is connected, the parameter is the difference between the "B+ Voltage" and the "B- Voltage" measured values.	Volts
Battery Current	Value calculated from the "Battery Shunt Voltage Drop" and the "Battery Shunt Resistance" parameters	Amps
Alternator Current	Value calculated from the "Alternator Shunt Voltage Drop" and the "Alternator Shunt Resistance" parameters	Amps
Load Current	Difference between the "Battery Current" and the "Alternator Current" parameters.	Amps
FRS Value	Field Reduction Switch value set to limit the alternator output	%
Set Field Limit	Limitation of the alternator output due to immediate operating conditions.	%
Set Slave Field Limit	Limitation of the alternator output when there are two X regulators in the system and the given regulator acts as a "Slave".	%

Regulator State parameters are dynamically calculated values according to the current operating conditions.

Parameter	Meaning	Units
Running Time	Accumulated time since ignition was switched ON	-
Status	Regulation State - monitoring / charging	-
Digital Field Output	Set alternator output	%
Regulation Target	Voltage at Battery	Volts
Set Minimum Field	Lower limit of field output	%
Set Maximum Field	Upper limit of field output	%
Wiring Voltage Drop	Measured voltage drop to batteries from alternator	Volts

4. NMEA-2000 interface

PRO X Regulators can be connected to an existing NMEA-2000 network allowing current regulator status to be displayed on the vessel's displays.

Network credentials are as following:

- NMEA2000 VID = 1127 decimal or 0x0467 hex
- NMEA2000 PID = 25936 decimal or 0x6550 hex
- NMEA2000 Product Name = Electromaax X
- NMEA2000 Function Code = 141
- NMEA2000 Class Code = 35
- NMEA2000 Software Version = 1.0
- NMEA2000 Standard = 3.101

The X regulator reports the state of the "DC Sources" such as:

- a) "DC source #0" shows the following values:
 - Alternator Voltage
 - Alternator Temperature
 - Engine RPM
- b) "DC Source #1" shows the following values from another X regulator connected to the given X regulator:
 - Peer Alternator Voltage
 - Peer Alternator Temperature
 - Peer Engine RPM
- c) "DC Source #2" shows the following values:
 - Alternator Current
 - Peer Alternator Current
 - Battery Current
 - Load Current
 - Load Voltage
 - Battery Temperature
 - Battery Voltage

The following PGNs are transmitted over the network:

- PGN127506()
- PGN127508()
- PGN127751()

EMx.exe allows monitoring the raw CAN network frames when the NMEA-2000 network is connected and enabled in the device settings.

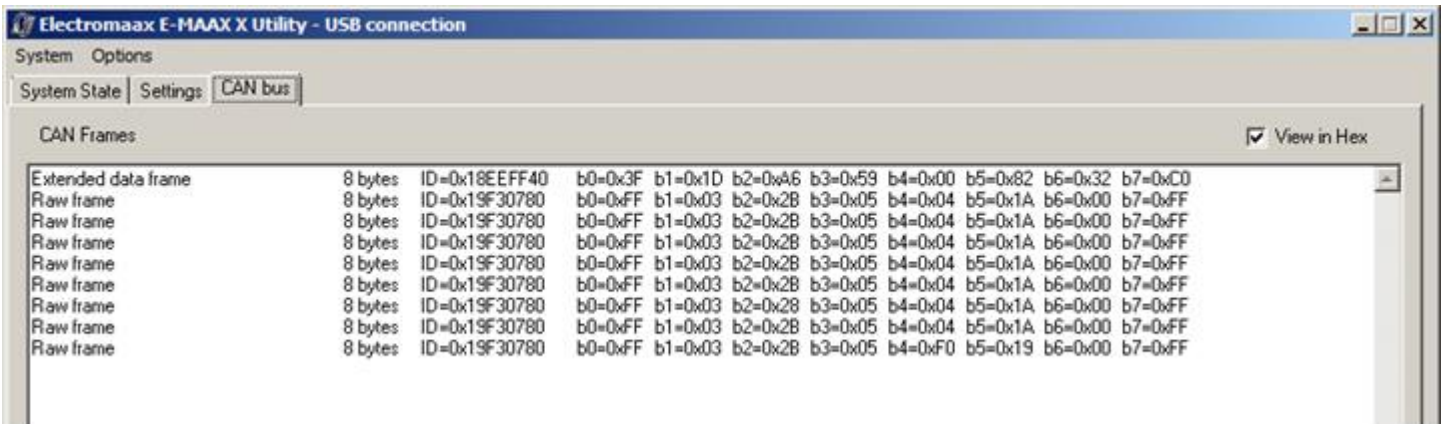

4. Wi-Fi interface

Wi-Fi interface is the only way for a user to observe the system state and change its settings.

When using the PRO X regulator Wi-Fi in Access Point Mode (the “Wi-Fi Mode” parameter is set to 2), the PRO X regulator creates its own wireless network, and acts as a dynamic server on it. SSID of the network is set as the value of the “Wi-Fi SSID” parameter. Access Point Mode does not require any passwords to connect to it. The local IP address of the server is set as the value of the “Wi-Fi AP IP Address” parameter.

In order to connect to it, users run an internet browser on any platform, and type the local IP address in the address bar.

When using the PRO X regulator Wi-Fi in Station Mode (the “Wi-Fi Mode” parameter is set to 1), the PRO X regulator connects to an existing wireless network as a device, and acts as a dynamic server on it. The “Wi-Fi SSID” and “Wi-Fi STA Password” parameters must be set according to the wireless network’s settings.

The local IP address of the PRO X regulator’s web server is set by the host network it is connected to. The “Wi-Fi AP IP Address” parameter has no meaning in the Station Mode. The network router would show the local IP address of the X regulator under the value of the “Device Name” parameter.

The PRO X Regulator tries to connect to an existing network for 10 seconds. If the connection was not successful, it defaults to the Access Point Mode with the network SSID “EMAAX-X” and no password. Local IP address is set to “192.168.0.1”. This is to allow the users to revise the connection settings and try to connect again.

Remote Support is an option when users can allow the system state and settings to be viewed and modified remotely via Internet by the system supplier. This only works when the PRO X Regulator is connected in the Station Mode to a local wireless network with Internet access. Typical example of use would be a cell phone with a Wi-Fi HotSpot and cell data enabled at the same time.

Table below shows the parameters of the Wi-Fi transceiver of the PRO X regulators:

Parameter	Value	Units
Center frequency range	2412 .. 2484	MHz
Wi-Fi wireless standard	IEEE 802.11b/g	-
Data rate at 20MHz 11b	1, 2, 5.5, 11	Mbps
Data rate at 20MHz 11g	6, 9, 12, 18, 24, 36, 48, 54	Mbps
Antenna type	PCB trace antenna	-
TX Power 11b at 1 Mbps	19.5	dBm
TX Power 11b, 11 Mbps	19.5	dBm
TX Power 11g, 6 Mbps	18	dBm
TX Power 11g, 54 Mbps	14	dBm



In order to view the information on the regulator’s website, users run an internet explorer on any platform, and type the local IP address in the address bar. When a gauge is grayed out, it means that there is no corresponding input. Field Reduction Switch buttons “FRS+” and “FRS-” appear when the PRO X regulator is in charging mode. Remote Support is enabled by clicking “Share Data with Support” button in the “About” section of the website.



Menu ElectroMaax E-MAAX X 192.168.0.1

Not secure

Gauges View **Tables View** **Settings** **About**

Battery

13.5 voltage V	35.1 current A	22.0 temp C	86.0 load current A
--------------------------	--------------------------	-----------------------	-------------------------------

This Regulator [X Regulator]

50.9 alt current A	25.8 alt temp C	100 field %	0 engine RPM
------------------------------	---------------------------	-----------------------	------------------------

System is charging: Bulk/Absorb
CAN bus connected

FRS+ **FRS-**

Peer Regulator [right]

---	---	---	---
alt current A	alt temp C	field %	engine RPM

System is monitoring
Regulator is Slave

Reference Connection diagrams

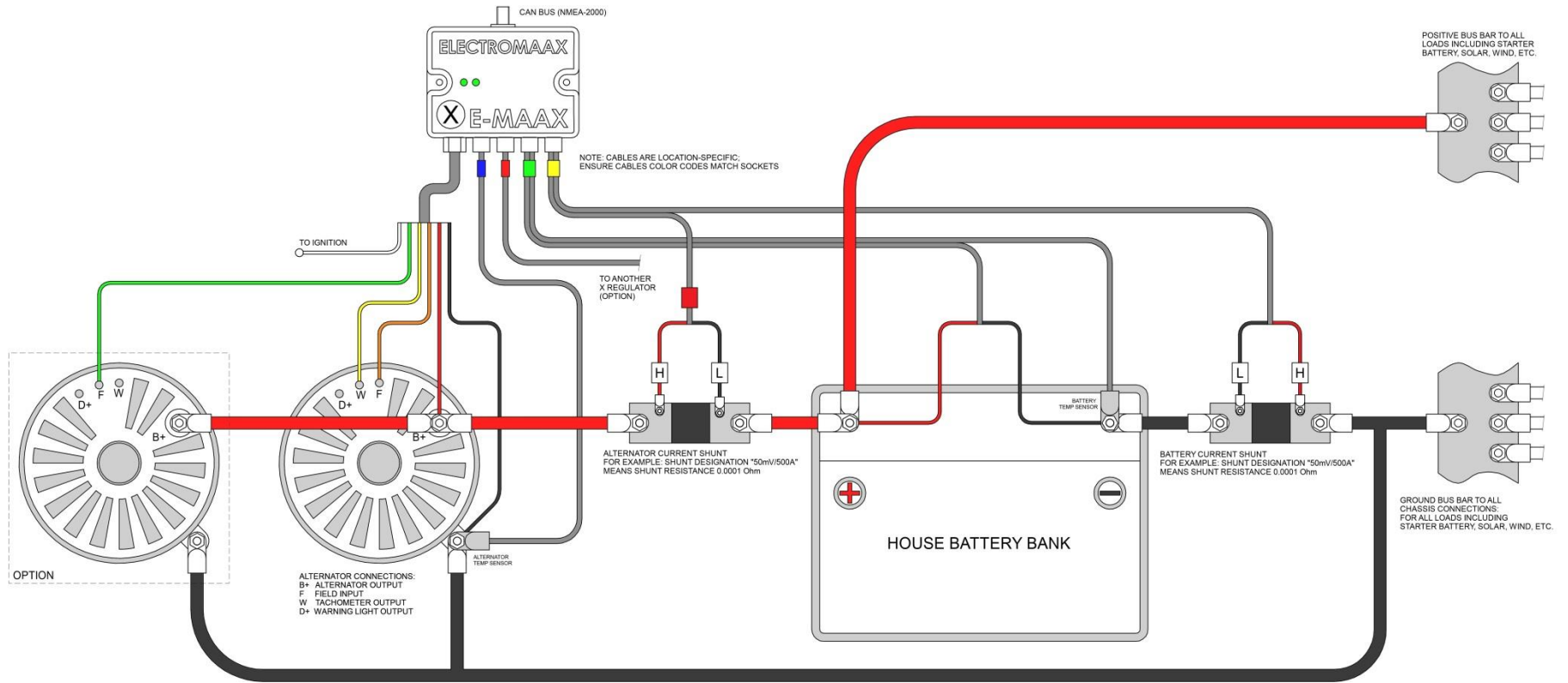

System with Remote Rectifier

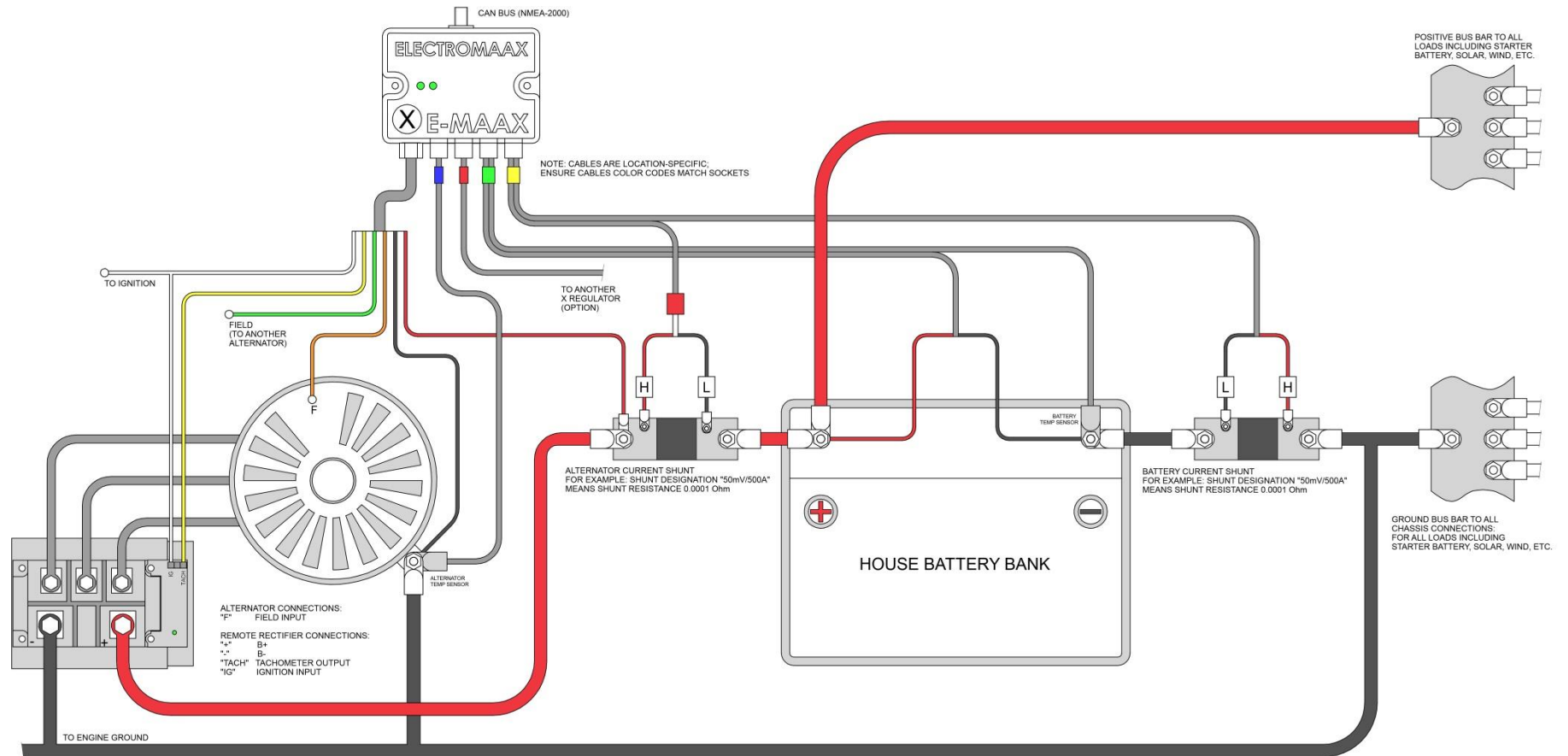

Notice

ElectroMaax reserves the right to make product modifications or discontinue products without notice. Customers are advised to obtain latest written specifications prior to ordering products. Information provided by ElectroMaax is believed to be accurate at the time of its release. Products sales are subject to the ElectroMaax Terms of Sales in force at the time of order acknowledgment. ElectroMaax products are not designed, authorized, or warranted for use in life support devices and systems, or any other critical applications which may involve death, injury, property or environmental damages. Using ElectroMaax products for any critical application is fully at the risk of the customers and their end users and assigns.